

SHOP BILL

QTY.	SECTION DESCRIPTION	LENGTH		MARK	REMARKS
		FEET	INCHES		
ONE	BEAM			30B1	
1	W 21 x 44	29	11		
4	L 3½ x 3½ x 5/16	1	2½	aa7	
FIVE	BEAM			30B2	
5	W 18 x 35	31	0 5/8		
FOUR	BEAM			30B3	
4	W 18 x 35	31	0 5/8		
TWO	BEAM			30B4	
2	W 14 x 43	31	0 5/8		

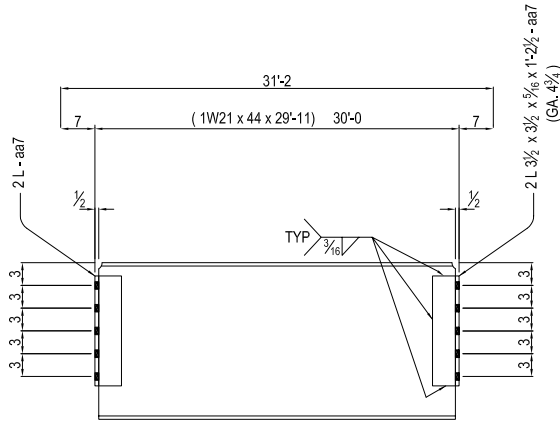

1 - BEAM - 30B1

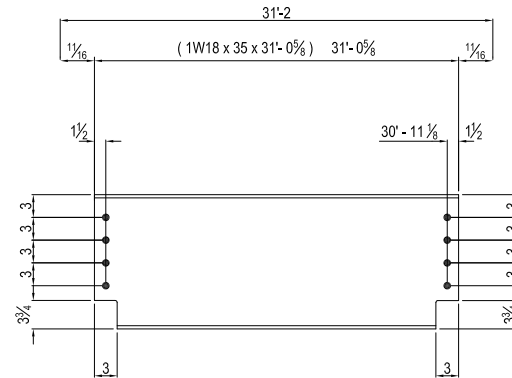

5 - BEAMS - 30B2

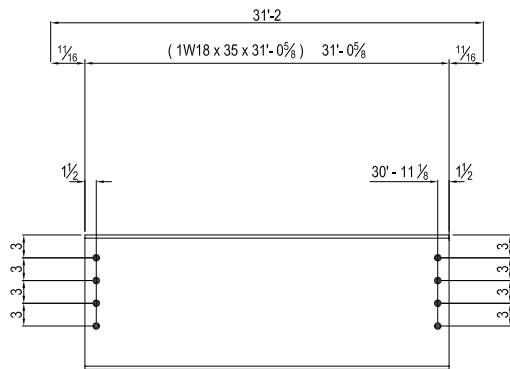

4 - BEAMS - 30B3

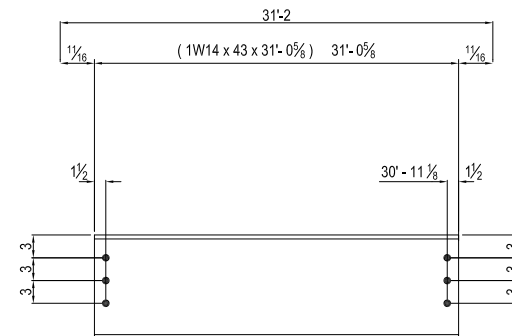

2 - BEAMS - 30B4

PROJECT: A NEW FACILITY FOR FIRST
COMMUNITY BANCSHARES, INC.
SEARCHY, ARKANSAS
ARCH: ROARK, PARKINS, PERRY, YELVINGTON
CONTRACTOR

PAINT: NONE	SCALE: 1/8" = 1'-0"	DRAWN BY:
EDGE DIST: 1/4 U/N	JOB #	SHT. 30
HOLES: 13/16 U/N		